

HunterDouglas

Installation • Operation • Care



Duette® and Applause®
Honeycomb Shades
Vertiglide™ System

CONTENTS

Getting Started:

Product View 1
Tools and Fasteners Needed 2

Installation:

Installation Overview 3
Outside Mount — Mount the Installation Brackets 5
Inside/Ceiling Mount — Mount the Installation Brackets.. 7
Prepare the Vertical Rails..... 8
Install the Vertical Rails into the Headrail..... 11
Install the Headrail 14
Attach the Stationary Rail Bottom Bracket..... 15
Final Shade Adjustments 17
Valance Attachment 19
Handle Attachment..... 21

Operation:

Troubleshooting 22

Care:

Removing the Shade (If Necessary) 24
Cleaning Procedures 24

Questions?

Call the Hunter Douglas Customer Information Center at
1-888-501-8364.



GETTING STARTED

Product View

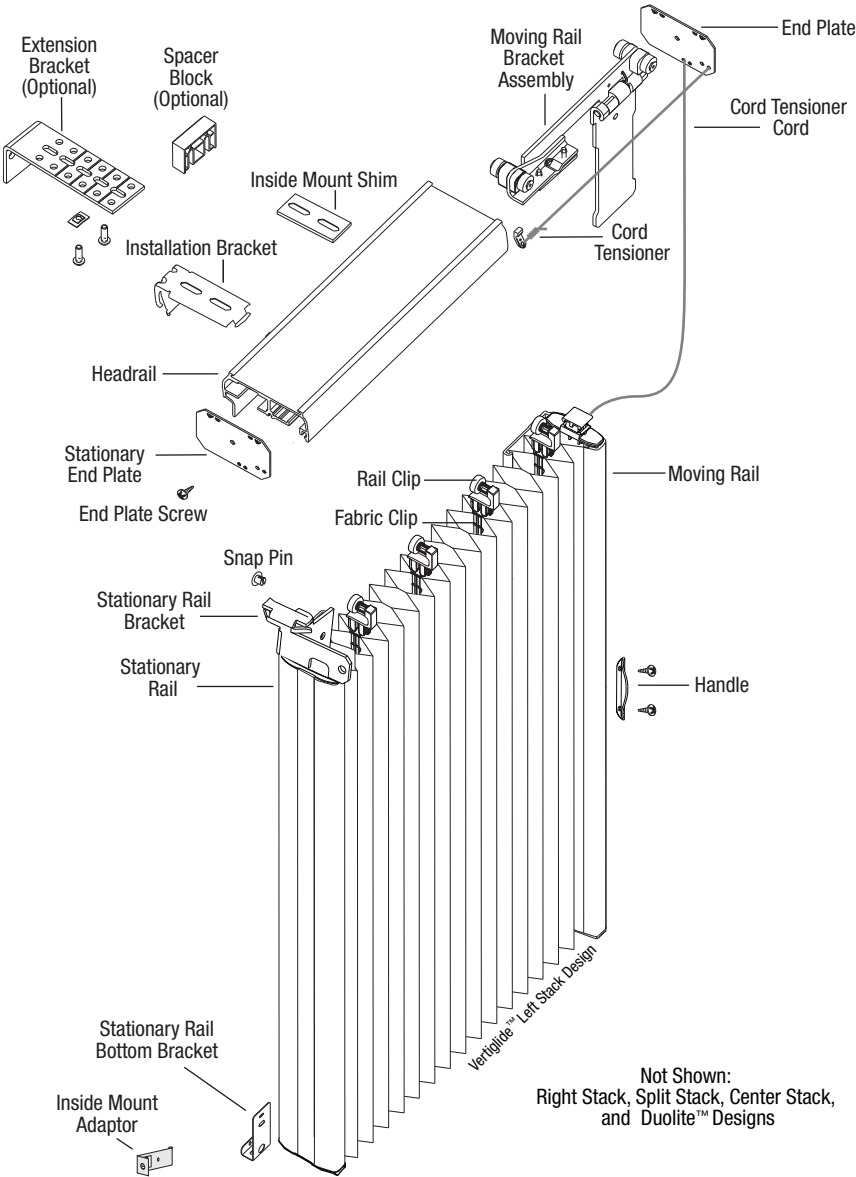

GETTING STARTED

Thank you for purchasing Hunter Douglas Duette® or Applause® Vertiglide™ honeycomb shades. With proper installation, operation, and care, your new shades will provide years of beauty and performance.

Please thoroughly review this instruction booklet and the enclosed packing list before beginning the installation.

Tools and Fasteners Needed

- Flat blade and Phillips screwdriver
- Mallet, plastic or rubber
- Power drill, $\frac{3}{32}$ " drill bit, and a $\frac{1}{4}$ " hex driver
- Level (laser level is recommended)
- Measuring tape and pencil
- Scissors

In addition, you will need fasteners designed to work with your specific mounting surface(s).

- **#6 Hex Head Screws (Provided).** Two $1\frac{1}{2}$ " screws are provided per installation bracket.
- **Longer #6 Hex Head Screws (Not Provided).** If using spacer blocks, use #6 screws long enough for a secure attachment.
- **Speed Nuts and Screws (Provided).** Extension brackets come with speed nuts and screws.
- **Drywall Anchors (Not Provided).** Use drywall anchors when mounting into drywall.



#6 x $1\frac{1}{2}$ "
Hex Head Screw
(Provided)



Longer #6 Hex Head Screw
for Use with Spacer Blocks
(Not Provided)



Speed Nut
and Screw
(Provided with Each
Extension Bracket)

GETTING STARTED

Installation Overview

Installation for Vertiglide™ shades varies based on the shade's mounting type, the design to be installed, and the valance type selected. Refer to the packaging label to determine each.

Mounting Types and Window Terminology

- Review the mounting designs and basic window terminology illustrated below. Determine if your shade is an inside mount, outside mount, or ceiling mount (mounting directly into the ceiling).

NOTE: For ceiling mount applications, refer to the inside mount instructions.

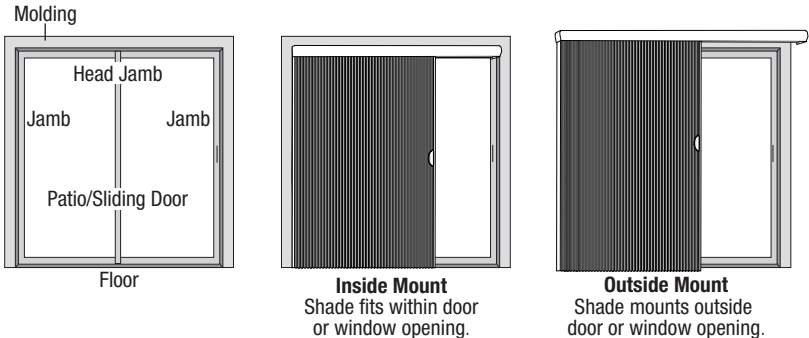

Shade Designs

- Determine which Vertiglide design you are installing: left stack, right stack, split stack (center opening), center stack, or Vertiglide Duolite™.

NOTE: The icons illustrated in the chart below appear throughout this document to indicate instructions specific to that shade design.

Vertiglide™ Design	Number of Stationary Rails	Number of Moving Rails	Vertiglide Design	Number of Stationary Rails	Number of Moving Rails
<p>Left Stack</p>	1	1	<p>Split Stack (Center Opening) and Duolite</p>	2	2
<p>Right Stack</p>	1	1	<p>Center Stack</p>	0	2

GETTING STARTED

Valance Types

- Determine the type of valance you are installing with your shade: Sydney (aluminum) or Everwood® Grandover™ (alternative wood).

Sydney Aluminum Valance

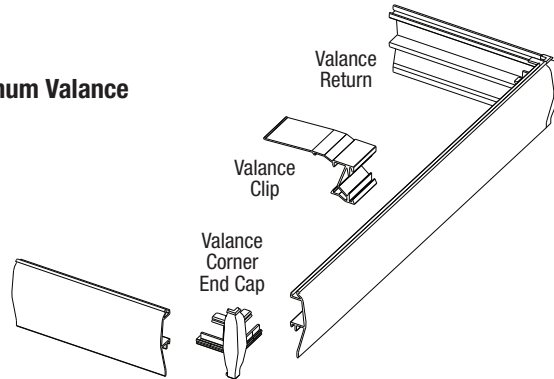

Everwood® Grandover™ Alternative Wood Valance

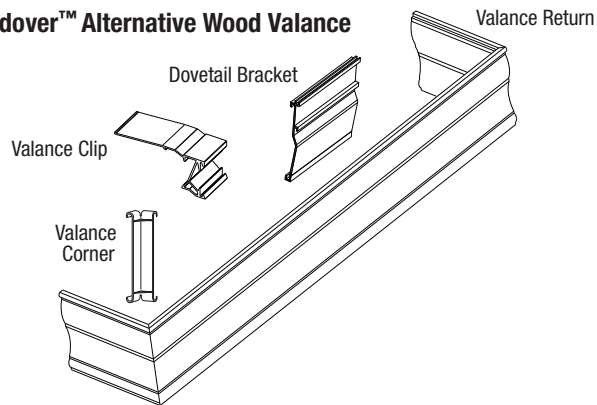

Installation Brackets Required

- The number of installation brackets required varies with headrail width, as shown.

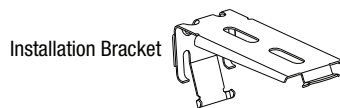

Shade Width	Brackets Required
12" – 31"	2
31 1/8" – 66"	3
66 1/8" – 96"	4
96 1/8" – 139"	5
139 1/8" – 168"	6

Next Step

- Refer to the page below based on your shade type:
 - Outside Mount, see page 5.
 - Inside/Ceiling Mount, see page 7.

INSTALLATION

Outside Mount — Mount the Installation Brackets

- Center the headrail over the window opening at the desired height. Use a pencil to lightly mark each end of the headrail.
 - Alternatively, measure the width of the headrail and use that width to mark the headrail end points over the window opening.

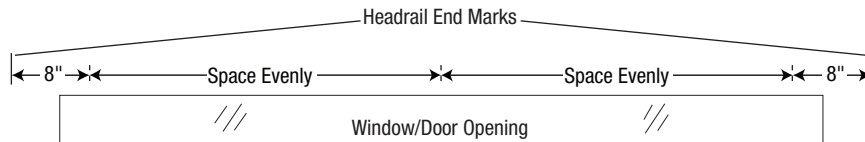

- Mark 8" in from each end of the headrail.
 - If more than two installation brackets came with your order, space additional bracket(s) evenly between the two end brackets and mark their location. Mount into studs whenever possible.
- Determine where to place the top of the installation brackets.
 - Add the desired floor clearance to the ordered height of the shade. The ordered height can be found on the packaging label. A minimum of $\frac{1}{2}$ " floor clearance is recommended.
 - Measure this total distance up from the floor. This is where to place the top of the installation brackets.
 - A minimum flat vertical surface of $\frac{5}{8}$ " is required to mount the brackets.

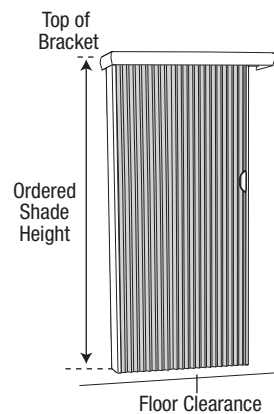

CAUTION: The rear of the brackets must be flush against a flat mounting surface. Do not mount brackets on curved molding.

- If you ordered spacer blocks or extension brackets, see the next page.

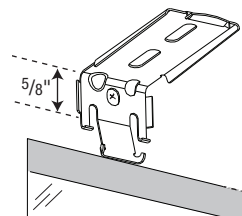

- Center the brackets on your marks and mark the screw holes.

IMPORTANT: Be sure the front edges of the installation brackets are level and aligned to each other.

CAUTION: Use wall anchors when mounting into drywall. Wall anchors are not provided.

- Drill the screw holes using a $\frac{3}{32}$ " drill bit.
- Attach the installation brackets using the screws provided.

INSTALLATION

Spacer Blocks for Additional Clearance

- If using spacer blocks, position each spacer block with the solid side facing the mounting surface.

- Each spacer block projects the installation bracket $\frac{1}{2}$ " away from the mounting surface.



IMPORTANT: Use a maximum of three spacer blocks ($1\frac{1}{2}$ " per installation bracket).

- Attach the installation brackets and spacer blocks using #6 mounting screws long enough for a secure installation. Longer screws are not provided.

CAUTION: The rear of the installation brackets must be flush against a flat surface. Do not mount installation brackets on curved molding.

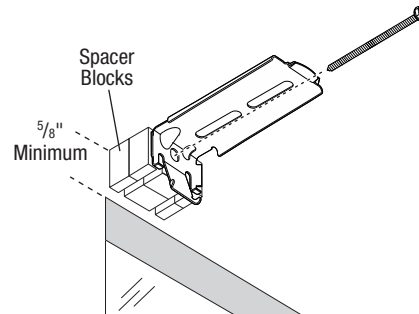

Extension Brackets for Additional Clearance

- If you need more than $1\frac{1}{2}$ " of clearance, use extension brackets. When using extension brackets, mark two screw holes per bracket.

CAUTION: The rear of the extension brackets must be flush against a flat surface. Do not mount extension brackets on curved molding.

IMPORTANT: Use drywall anchors when mounting into drywall. Drywall anchors are not provided.

- Attach the extension brackets using the screws provided.
- Attach the installation brackets to the extension brackets using the screws and speed nuts provided.

IMPORTANT: Be sure the front edges of the installation brackets are level and aligned to each other.

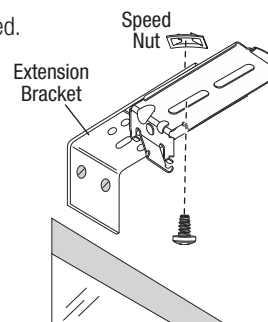
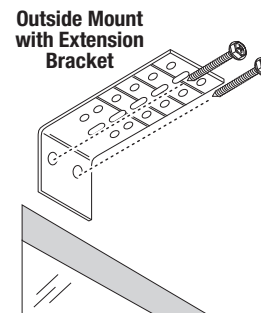

Proceed to "Prepare the Vertical Rails" on page 8.

INSTALLATION

Inside/Ceiling Mount — Mount the Installation Brackets

- Snap the shim onto the top of the installation bracket.

CAUTION: You *must* attach shims to the installation brackets to allow for valance attachment. If you are not installing a valance, shims are not necessary.

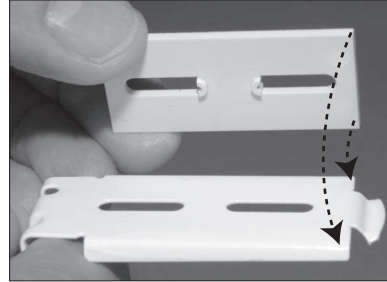

- Mark 8" in from each jamb.
 - If more than two installation brackets came with your order, space additional bracket(s) evenly between the two end brackets and mark their location. Mount into wood whenever possible.

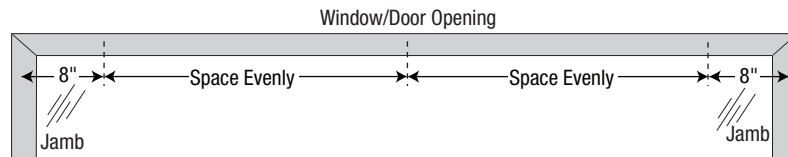

- Measure and mark all bracket locations.
 - A minimum depth of $1\frac{5}{16}$ " is required to attach the brackets.
 - For fully recessed mounting, refer to the table below for the minimum depth required.
 - Mark one screw hole per bracket.

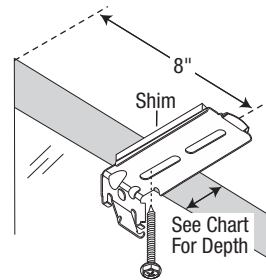

NOTE: Use drywall anchors when mounting into drywall. Drywall anchors are not provided.

Valance Type	Minimum Depth for Fully Recessed Mount ($\frac{3}{4}$ " Pleat Size)	Minimum Depth for Fully Recessed Mount ($1\frac{1}{4}$ " Pleat Size)
Aluminum	$3\frac{5}{8}$ "	$4\frac{1}{8}$ "
Alternative Wood	4"	$4\frac{1}{2}$ "

- Drill the screw holes using a $\frac{3}{32}$ " drill bit.
- Attach the installation brackets using the screws provided.

IMPORTANT: Be sure the front edges of the installation brackets are level and aligned to each other.

Proceed to "Prepare the Vertical Rails" on page 8.

INSTALLATION

Prepare the Vertical Rails

- Gather and layout all the components for installation on a clean, cloth covered surface.



Install the Stationary Rail Bottom Bracket into the Stationary Rail

Side Stack (Left and Right), Split Stack, and Duolite™

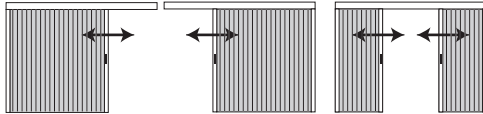

- Insert the stationary rail bottom bracket into the bottom of the stationary rail. (For Split Stack and Duolite designs, insert a bottom bracket into each stationary rail.) The base of the bottom bracket should extend toward the window.

NOTE: Do not insert the bracket completely. Leave at least $\frac{1}{4}$ " of the bracket showing below the stationary rail.

NOTE: Do not attach the bracket to the mounting surface at this time.

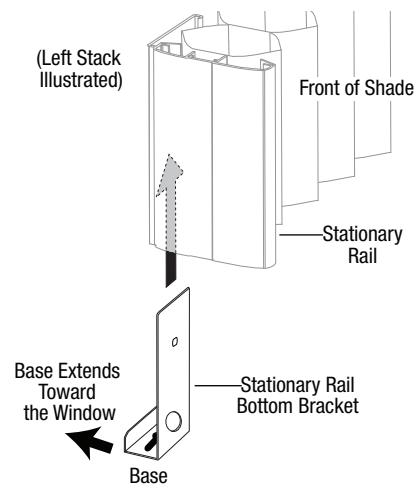

INSTALLATION

Install the Moving Rail Bracket(s) into the Top of the Moving Rails

Side Stack (Left and Right), Split Stack, Duolite™, and Center Stack

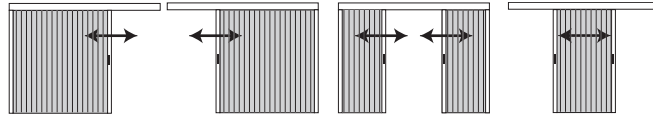

Moving Rail Bracket
(Left Stack Shown)

- Insert the bottom end of the moving rail bracket into the top of the moving rail.

- **Split Stack, Duolite, and Center Stack designs:** Insert a moving rail bracket into each moving rail.

NOTE: For Split Stack an Duolite designs, the right moving bracket is labeled “Left Stack” and the left moving rail bracket is labeled “Right Stack”.

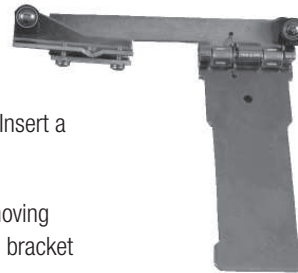

- If attached, remove the snap pin located in the moving rail.



Snap Pin



- Slide the moving rail bracket into the moving rail.

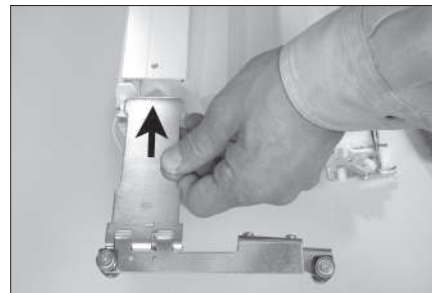

- Align the hole in the bracket with the hole in the moving rail.

- Push the snap pin through both the moving rail and the moving rail bracket.

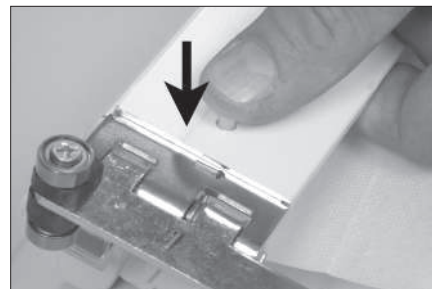

INSTALLATION

Install the Center Pull Plate

Split Stack Only

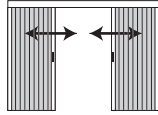

- Measure and mark the center of the headrail on the cord tensioner channel.

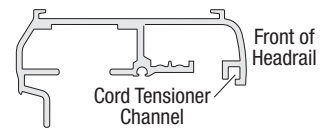
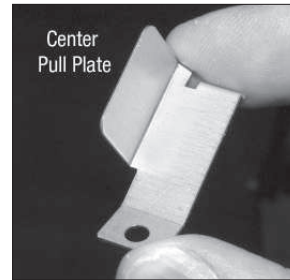

- Position the center pull plate on the underside of the headrail as shown.
- Align the plate to the center mark.

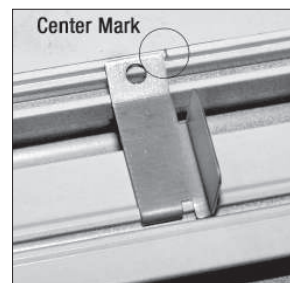

- Attach the center pull plate with a screw into the cord tensioner channel.

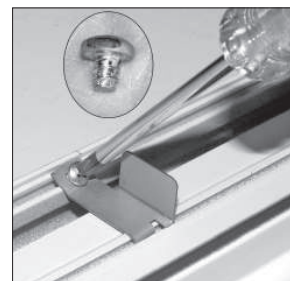

Install the Vertical Rails into the Headrail

Side Stack (Left and Right), Split Stack, Duolite™, and Center Stack

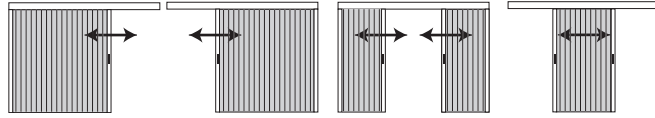

Remove the End Plate

- Remove any end plates that are attached to the headrail. See illustration.

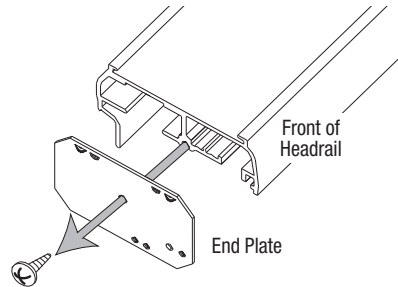

Install the Moving Rail Bracket(s) and Rail Clips into the Headrail

- Pick up both vertical rails and fabric as one unit.
- Slide the rollers of the moving rail bracket into the rear track of the headrail.
- Slide the rail clips into the front track in the headrail.
- **Split Stack and Duolite designs:** Repeat the above steps to install the moving rail bracket and rail clips for the second fabric panel into the other end of the headrail.
- **Center Stack design:** Slide the second moving rail bracket into the rear track.

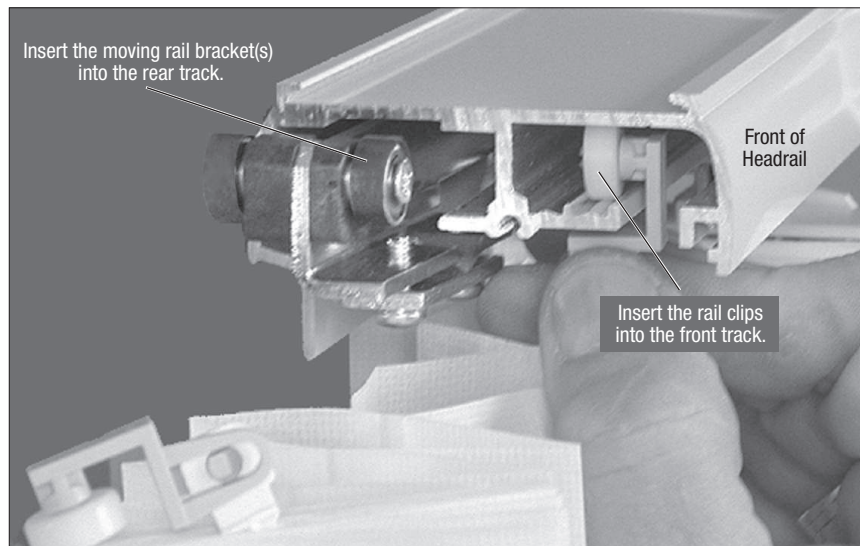

INSTALLATION

Install the Stationary Rail

Side Stack (Left and Right), Split Stack, and Duolite™

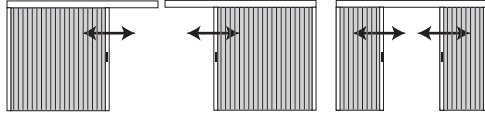

- The stationary rail bracket has two slots at the top. The rear tracks of the headrail fit into these slots.

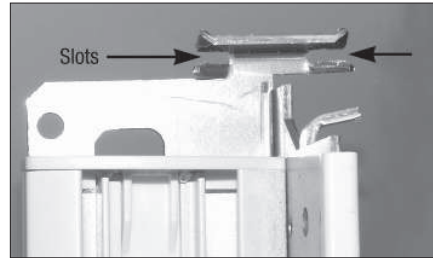

- Insert the stationary rail bracket onto the back track of the headrail as shown. Use a mallet to tap into place.
 - Make sure the stationary rail bracket is flush with the end of the headrail.
 - **Split Stack and Duolite designs:** Repeat the above steps to attach the second stationary rail to the other end of the headrail.

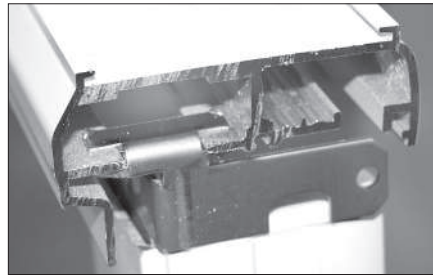

- Reattach the stationary rail side end plate with the hole toward the front of the headrail.

- **Split Stack and Duolite designs:** Only attach the left end plate (the end plate *without* the cord tensioner attached).

IMPORTANT: The stationary rail bracket *must* butt up against the end plate. If necessary, gently tap the bracket toward the end plate.

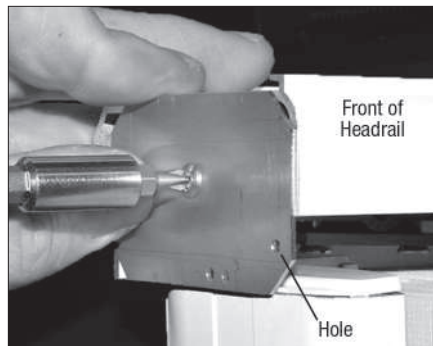

Install the Cord Tensioner

Side Stack (Left and Right), Split Stack, Duolite™, and Center Stack

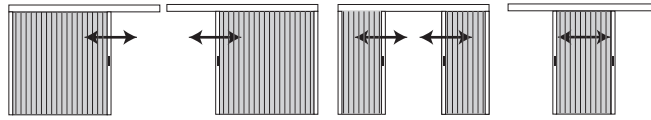

- Unwind the cord from the unattached, remaining end plate.



- Slide the cord tensioner into the channel at the front of the headrail.

NOTE: You will adjust the cord tensioner later.

- Remove the end plate screw from the center channel in the headrail.

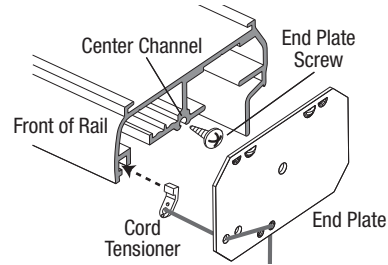

- Use the screw to attach the end plate with the holes toward the front of the headrail.

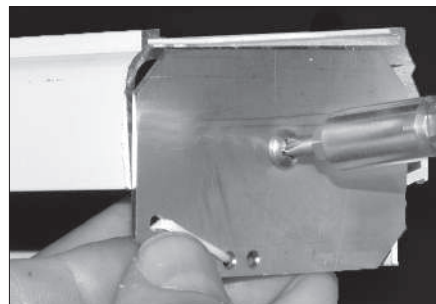

Center Stack Only

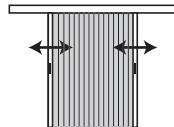

- Attach the other end plate to the headrail.

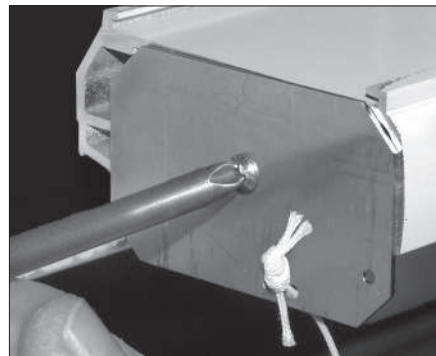

INSTALLATION

Install the Headrail

IMPORTANT: Larger installations will require two people.

Side Stack (Left and Right), Split Stack, Duolite™, and Center Stack

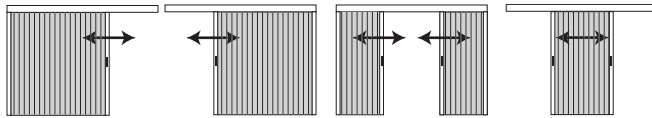

NOTE: Once the headrail has been installed, it cannot easily be adjusted by sliding it in the installation brackets.

- Measure and mark the center point on the mounting surface.
- Measure and mark the headrail's center point.
- Align the headrail by matching the marks.



- Slip the headrail into the installation brackets, with the front of the bracket fitting under the groove of the headrail.
- Push the headrail back and up until it snaps into place.

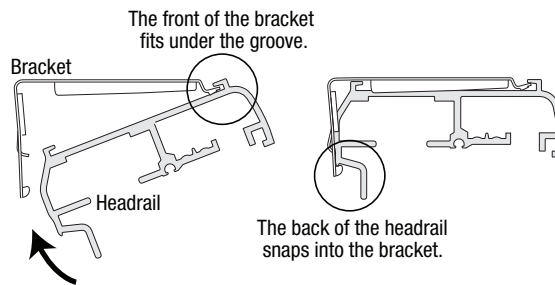

- Inspect the installation brackets to verify the back of the headrail is securely snapped into the base of each bracket. Also, the front edge of **each** bracket must be in the groove of the headrail. If any brackets are NOT installed correctly, release the shade and reinstall. If necessary, see "Removing the Shade (If Necessary)" on page 24.

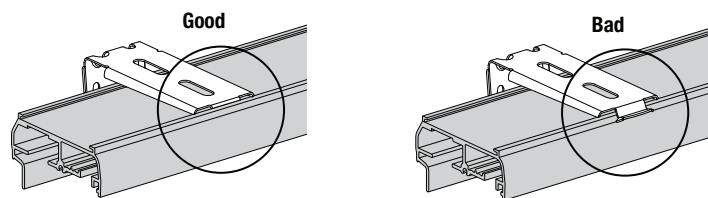

Attach the Stationary Rail Bottom Bracket

Side Stack (Left and Right), Split Stack, and Duolite™

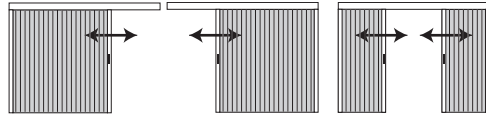

Outside Mount

Attaching the stationary rail bracket(s) to the floor

- Use a level to ensure that the stationary rail is exactly vertical when viewed from both the front and the side.
- Attach the bracket using the screw provided.

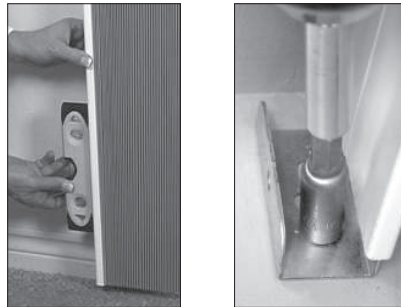

Attaching the stationary rail bracket(s) to the wall

- Use a level to ensure that the stationary rail is vertical.
- Attach the bracket using the screw provided.

IMPORTANT: Use drywall anchors when mounting into drywall. Drywall anchors are not provided.

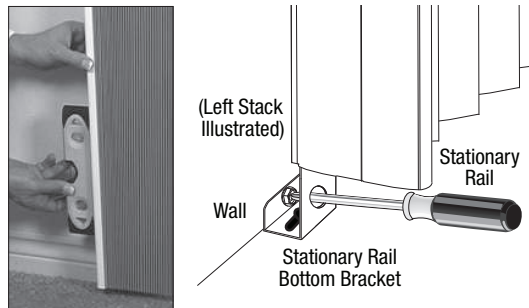

- You may use an extension bracket to mount the stationary rail away from the wall. An extension bracket may be necessary if you used spacer blocks or extension brackets with the installation brackets.

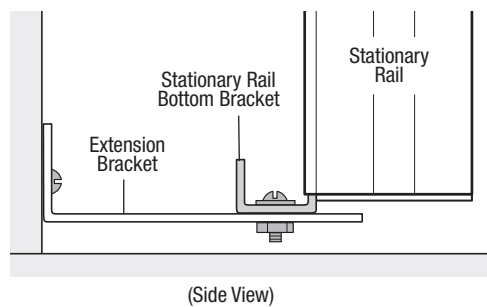

INSTALLATION

Inside Mount

Attaching the stationary rail bracket to the floor

- Place a screw through the bracket and into the floor. See the next step if you ordered your shade with a cut-out or if you prefer to secure the rail to the wall.

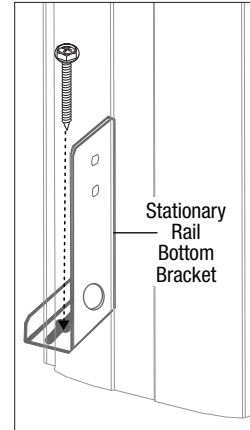

Attaching the stationary rail bracket to the wall

- Use the inside mount adaptor to secure the stationary rail to the side of the jamb.

NOTE: If you ordered your shade with a cut-out, for baseboards or other obstructions, you **must** use the inside mount adaptor.

- Slide the inside mount adaptor onto the stationary rail bottom bracket. Align the screw hole of the adaptor to face the side jamb (or side wall).
- Secure with a screw through the inside mount adaptor and into the side jamb.

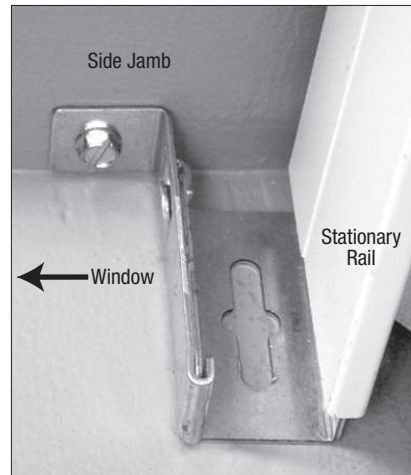

Final Shade Adjustments

Remove Excess Cord

- Pull on the end of the cord at the cord tensioner to release the slip knot.
- With the cord tensioner approximately 12" from the end plate, pull on the cord to create tension.
- Re-tie a square knot at the cord tensioner.
- Trim the excess cord.

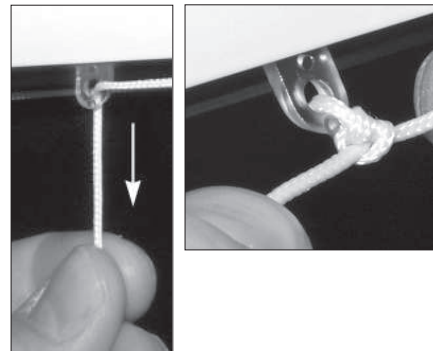
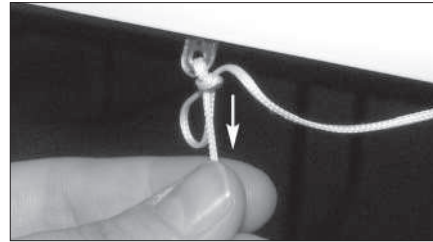

Adjust the Cord Tension

Test the Shade

- Slide the moving rail back and forth to check the shade tension. The moving rail should slide easily, yet there should be enough cord tension to hold the shade in place at any position.
- Increase the cord tension if the rail does not hold its position.
 - Slide the cord tensioner away from the end plate until you feel resistance.
 - Continue to slide the cord in 1" increments until the moving rail holds its position.
- Decrease the cord tension if the moving rail does not move smoothly.
 - Slide the cord tensioner toward the end plate until you feel the tension lessen.

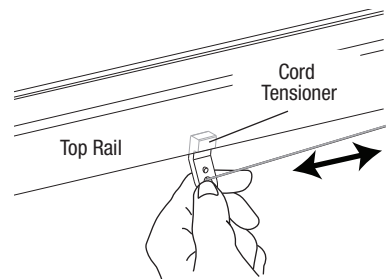

INSTALLATION

Adjust the Vertical Alignment

- Check to see if the moving rail is aligned.
- If not, locate the adjustment lever attached to the moving rail bracket.
 - To access the lever, carefully push back the top of the fabric on the moving rail side of the shade.

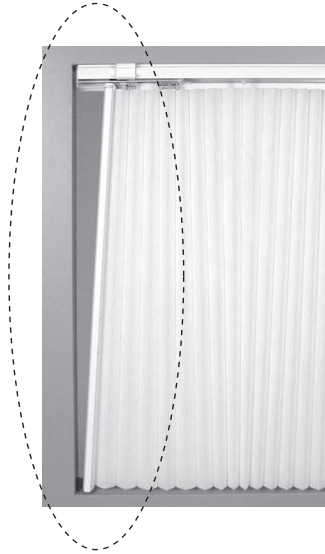
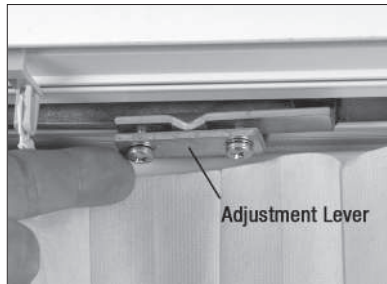

To Adjust the Bottom End of the Moving Rail to the Right

- Loosen the left screw $\frac{1}{2}$ turn, then tighten the right screw $\frac{1}{2}$ turn. Repeat until the shade is properly aligned.
- After adjustment, tighten both screws completely.



To Adjust the Bottom of the Moving Rail to the Left

- Loosen the right screw $\frac{1}{2}$ turn, then tighten the left screw $\frac{1}{2}$ turn. Repeat until the shade is properly aligned.
- After adjustment, tighten both screws completely.



INSTALLATION

Valance Attachment

- Attach the valance clips to the headrail.
 - Slide the valance clip under the back lip of the headrail.
 - Rotate the valance clip down to snap it into place on the headrail.
 - Keep a minimum of 3" between the end of the headrail and the valance clips.

NOTE: Be sure to avoid areas where the headrail attaches to the installation brackets.

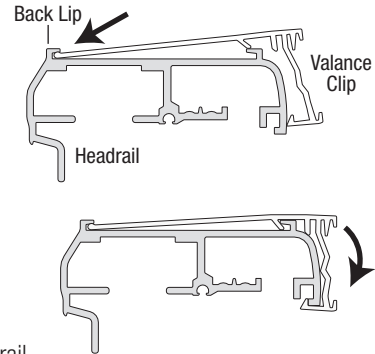

Aluminum Valance

- **Outside mounts and non-flush inside mounts only:** Attach the valance return to the valance.
 - Use the valance corner end cap to attach a return to each end of the valance.
- Attach the valance to the valance clips, as shown.
 - Insert the top of the valance into the top of the valance clip.
 - Rotate the valance down to snap it into place onto the headrail.
 - For wider shades, lay the two pieces of the valance on a flat surface and butt together.
 - Attach a valance clip at the seam to hold the two pieces together.

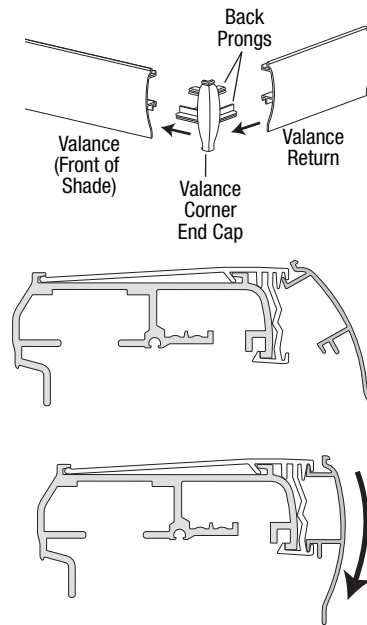

TIP: Tap the valance at each clip to assure that the valance is securely attached to the valance clips and the clips are securely attached to the headrail.



INSTALLATION

Alternative Wood Valance

■ **Outside mounts and non-flush inside mounts only:** Attach the valance returns.

- Use the valance corner brackets to attach a return to each end of the valance.
- Be sure the mitered corners are flush.

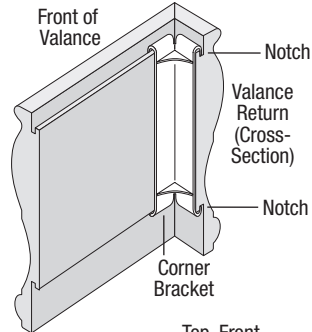

■ Attach the dovetail brackets to the valance so that they correspond to the positions of the valance clips on the headrail.

- Align the dovetail bracket so the long tab of the bracket is down.
- Place the top tooth of the dovetail bracket into the top groove on the valance. Snap the bracket down into place.

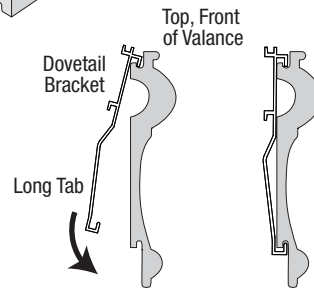

■ **Headrail widths over 168":** Lay the two pieces of the valance on a flat surface and connect them by placing a valance bracket at the seam.

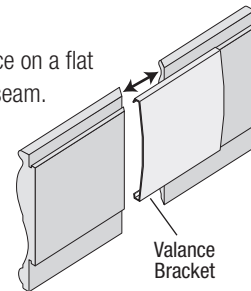

■ Attach the valance to the valance clips, as shown below.

- Insert the top of the valance into the top of the valance clip.
- Rotate the valance down to snap it into place onto the headrail.

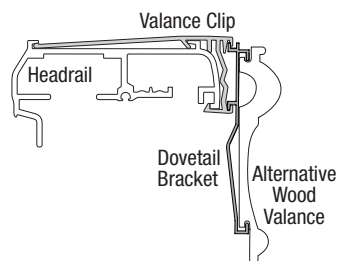
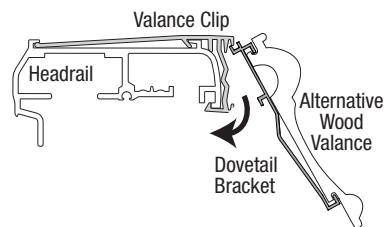

Handle Attachment

If the handle is not already attached to the moving rail, do the following:

- Position the handle so the holes on the flat portion of the handle are aligned with the screw holes on the moving rail. The curve of the handle should face out, away from the fabric.
- Attach the handle to its moving rail using the provided screws.
- **Split Stack and Duolite™ designs:** Repeat the above steps for the second moving rail.



OPERATION

Troubleshooting

Problem	Solution
The shade binds or moves with difficulty.	<ul style="list-style-type: none">■ Make sure that the shade fabric is not caught between the installation bracket and the headrail.■ Check that the headrail and installation brackets are level and aligned. Shim the installation brackets to level the headrail, if necessary. Shims are provided for inside and ceiling mounts.■ Check that the cord tensioner cord is not pinched.■ If the shade does not slide with ease, you may need to adjust the cord tension. Slide the cord tensioner away from the fabric stack slightly to decrease the tension. See “Adjust the Cord Tension” on page 17.
The shade does not stay in position.	<ul style="list-style-type: none">■ If the shade does not stay in position, you may need to adjust the cord tension. Slide the cord tensioner toward the fabric stack slightly to increase the tension. See “Adjust the Cord Tension” on page 17.
The shade is not vertically aligned.	<ul style="list-style-type: none">■ Check that the installation brackets are level and aligned. Shim the installation brackets to level the headrail, if necessary. Shims are not provided on outside mounts.■ Adjust the screws on the adjustment lever attached to the moving rail. See “Adjust the Vertical Alignment” on page 18.■ Check that the headrail is completely inserted into the installation brackets. See “Install the Headrail” on page 14.
The installation brackets do not allow enough clearance for the shade (to clear moldings or door handle(s)).	<ul style="list-style-type: none">■ With outside mounts, use extension brackets or spacer blocks for mounting each installation bracket to allow adequate clearance for your shade. See “Outside Mount — Mount the Installation Brackets” on page 6.■ With inside mounts, reposition the installation brackets to add clearance. See “Inside/Ceiling Mount — Mount the Installation Brackets” on page 7.

OPERATION

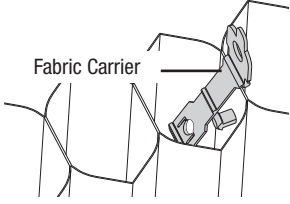
Problem	Solution
<p>On inside or ceiling mount applications, there isn't enough room above the mounted installation brackets to angle and attach the headrail and/or the valance.</p>	<ul style="list-style-type: none"> ■ Add a shim to each installation bracket to provide additional space to attach the headrail and/or valance. Shims are provided for inside and ceiling mounts. See "Inside/Ceiling Mount — Mount the Installation Brackets" on page 7.
<p>A fabric carrier needs to be reattached.</p>	<ul style="list-style-type: none"> ■ Place each carrier between a pair of fabric cells. ■ Align the hole in the fabric carrier with the hole in the fabric cells. ■ Snap the carrier closed by pinching the two pieces of the carrier together from top to bottom. 
<p>The cord tensioner does not lock into place.</p>	<ul style="list-style-type: none"> ■ Use a small 1/8" flat blade screwdriver and scrape the paint from the inside of the channel used for the cord tensioner. ■ Determine the correct location for the cord tensioner. Hold it in place and insert a small screw into the channel next to the cord tensioner. The small screw is not provided. ■ Place a valance bracket up against the cord tensioner to act as a stop, preventing the tensioner from sliding.
<p>The moving rail does not align with the stationary rail. The fabric seems to bow toward (or away) from the window.</p>	<ul style="list-style-type: none"> ■ Gently take the bottom of the moving rail(s) and angle it toward the window, then away from the window, then back into the correct position. The fabric should align to this correct position.

CARE

Removing the Shade (If Necessary)

You will need two people to remove the shade.

- First, grasp the top of the valance and rotate the valance downward to release the valance from the valance clips.

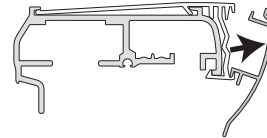
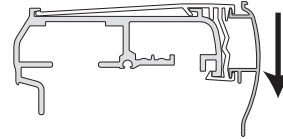

- Then, hold the headrail assembly and, using a small flatblade screwdriver, push back on the bottom tab of the installation bracket to release the headrail.

NOTE: Because the bracket may be stiff, the headrail may be difficult to remove. Twist the screwdriver blade slightly as you push back the bottom tab, to help remove the headrail from the bracket. Be careful not to scratch the finish on the back of the headrail.

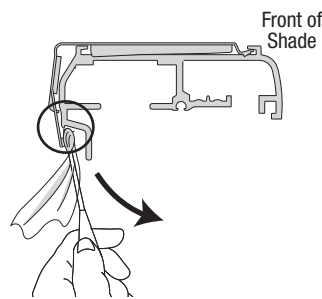

- Lift the shade assembly clear of the stationary rail bottom bracket.
- Place the entire Vertiglide™ shade assembly (headrail, vertical rails, and fabric panels) on the floor.
- To remove the fabric panels from the headrail for cleaning, reverse the steps stated in "Install the Vertical Rails into the Headrail" on page 11.

Cleaning Procedures

Hunter Douglas Duette® and Applause® honeycomb shades are made of anti-static, dust-resistant fabric which repels dirt and dust. For most honeycomb fabrics, the following cleaning options are available.

Dusting

- Regular light dusting with a feather duster is all the cleaning that is needed in most circumstances.

Vacuuming

CAUTION: Do not vacuum Architella® Elan® and Architella Elan Eclipse™ fabrics.

- For deeper cleaning, vacuum gently with a brush attachment.

Compressed Air/Hair Dryer (Cool Setting)

- Use compressed air or a hair-dryer on a cool setting to blow dust and dirt off shades.

Spot-Cleaning

CAUTION: Do not spot-clean Batiste, Opalessence™, and Royale fabrics.

- Prepare a solution of warm water and a mild detergent.
- Dampen a clean cloth in the solution and wring it out.
- Dab the spot with the dampened cloth until it is gone. Do not rub the fabric.
- Allow the shade to dry in the completely lowered position.

Bathtub Cleaning/Water Immersion

CAUTION: Do not immerse Commercial, Royale, and opaque fabrics.

- Immerse the shade in a basin or bathtub filled with warm water and a mild detergent. Never immerse the headrail into the solution.
- Rinse with clean water.
- Before removing from the rinse water, fully raise the shade and tilt it to allow excess water to drain off.
- Dry the shade completely in the lowered position.

Ultrasonic Cleaning

CAUTION: Do not ultrasonically clean Commercial, Opalessence™, Sunterra™ and opaque fabrics.

- Some honeycomb fabrics can be ultrasonically cleaned by a professional.
- Specify that a mild detergent solution be used.
- Never immerse the headrail into the solution.
- Dry the shade completely in the lowered position.

Injection/Extraction Cleaning

This type of professional cleaning injects a cleaning solution into the fabric and extracts the dirty solution in the same motion.

- Use only the dry method of injection/extraction for Applause® fabrics, as well as Duette® Architella®, Ariosa™, Commercial, Opalessence, Panache™, and opaque fabrics.
- If using injection/extraction for Batiste fabrics, specify that no chemicals are used (water only).



The Hunter Douglas® Lifetime Guarantee is an expression of our desire to provide a thoroughly satisfying experience when selecting, purchasing and living with your window fashion products. If you are not thoroughly satisfied, simply contact Hunter Douglas at (888) 501-8364 or visit hunterdouglas.com. In support of this policy of consumer satisfaction, we offer our Lifetime Limited Warranty as described below.

COVERED

BY A LIFETIME LIMITED WARRANTY

- Hunter Douglas window fashion products are covered for defects in materials, workmanship or failure to operate for as long as the original retail purchaser owns the product (unless shorter periods are provided below).
- All internal mechanisms.
- Components and brackets.
- Fabric delamination.
- Operational cords for a full 7 years from the date of purchase.
- Repairs and/or replacements will be made with like or similar parts or products.
- Hunter Douglas motorization components are covered for 5 years from the date of purchase.

NOT COVERED

BY A LIFETIME LIMITED WARRANTY

- Any conditions caused by normal wear and tear.
- Abuse, accidents, misuse or alterations to the product.
- Exposure to the elements (sun damage, wind, water/moisture) and discoloration or fading over time.
- Failure to follow our instructions with respect to measurement, proper installation, cleaning or maintenance.
- Shipping charges, cost of removal and reinstallation.

Hunter Douglas (or its licensed fabricator/distributor) will repair or replace the window fashion product or components found to be defective.

TO OBTAIN WARRANTY SERVICE

1. Contact your original dealer (place of purchase) for warranty assistance.
2. Visit hunterdouglas.com for additional warranty information, frequently asked questions and access to service locations.
3. Contact Hunter Douglas at (888) 501-8364 for technical support, certain parts free of charge, for assistance in obtaining warranty service or for further explanation of our warranty.

NOTE: In no event shall Hunter Douglas or its licensed fabricators/distributors be liable or responsible for incidental or consequential damages or for any other indirect damage, loss, cost or expense. Some states do not allow the exclusion or limitation of incidental or consequential damages, so the above exclusion or limitation may not apply to you. This warranty gives you specific legal rights, and you may also have other rights which vary from state to state.

Different warranty periods and terms apply for commercial products and applications.

HunterDouglas

hunterdouglas.com

